

HYDRONIC M-II

Technical description, installation,
operation and maintenance instructions.

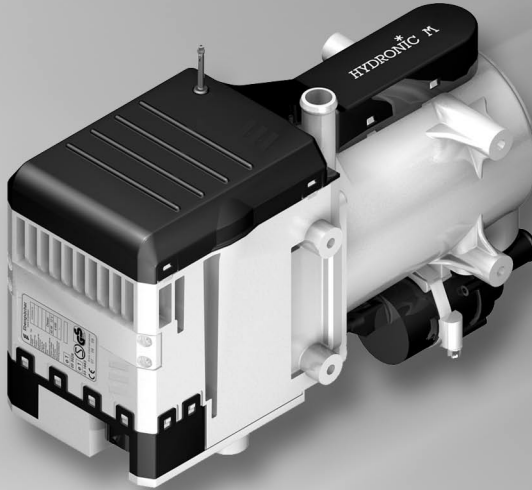

Heater	Order no.	Heater	Order no.
<i>HYDRONIC M8 Biodiesel</i>	12 V 25 2470 05 00 00	<i>HYDRONIC M12</i>	12 V 25 2472 05 00 00
	24 V 25 2471 05 00 00		24 V 25 2473 05 00 00
<i>HYDRONIC M10</i>	12 V 25 2434 05 00 00		
	24 V 25 2435 05 00 00		

**Water heater for diesel,
operating independently of the engine.**



Eberspächer
A world of comfort

1 Introduction

Contents

Chapter	Title	Contents
1	Introduction	<ul style="list-style-type: none"> • Contents..... 2 • Concept of this manual..... 3 • Special text structure, presentation and picture symbols..... 4 • Important information before starting work..... 4 • Statutory regulations..... 5, 6 • Safety instructions for installation and operation..... 7 • Accident prevention 7
2	Product information	<ul style="list-style-type: none"> • Scope of supply 8, 9 • Technical data..... 10 – 12 • Main dimensions..... 13
3	Installation	<ul style="list-style-type: none"> • Installation location 14 • Installing the 24 V heater in a vehicle for the transport of dangerous goods as per ADR / ADR 99 14 • Possible installation positions..... 15 • Mounting and fastening 15 • Nameplate..... 16 • Connection to the cooling water circuit..... 17 – 20 • Exhaust system 21 • Combustion air system..... 22 • Fuel supply 23 – 27
4	Operation and function	<ul style="list-style-type: none"> • Operating instructions 28 • Initial commissioning..... 28 • Important information for operation..... 28 • Description of functions 28 • Control and safety devices / EMERGENCY OFF 29
5	Electrical system	<ul style="list-style-type: none"> • Heater wiring 30 • Parts list for the circuit diagrams 30, 33, 35 • Circuit diagrams..... 31, 34, 36 – 39
6	Troubleshooting Maintenance Service	<ul style="list-style-type: none"> • In case of faults, please check the following points 40 • Troubleshooting 40 • Maintenance instructions 40 • Service 40
7	Environment	<ul style="list-style-type: none"> • Certification 41 • Disposal 41 • EU Declaration of Conformity..... 41
8	Lists	<ul style="list-style-type: none"> • List of key words 42, 43 • List of abbreviations..... 43



1 Introduction

Concept of this manual

This manual aims to support the service company installing the heater and to provide the user with all important information about the heater. The manual has been divided into 8 chapters to make it easier to find the corresponding information quickly.

1 Introduction

Here you will find important introductory information about installation of the heater and about the structure of the manual.

2 Product information

Here you will find information about the scope of supply, the technical data and the dimensions of the heater.

3 Installation

Here you will find important information and instructions referring to installation of the heater.

4 Operation and function

Here you will find information about the operation and function of the heater.

5 Electric system

Here you will find information about the electronic system and electronic components of the heater.

6 Troubleshooting / maintenance / service

This section contains information on possible faults and malfunctions, troubleshooting, maintenance and the service hotline.

7 Environment

Here you will find information about certification and disposal of the heater together with the EU Declaration of Conformity.

8 Lists

Here you will find the key word list and abbreviations list.

1 Introduction

Special text structure, presentation and picture symbols

This manual uses special text structures and picture symbols to emphasise different contents. Please refer to the examples below for the corresponding meanings and associated actions.

Special structure and presentations

A dot (•) indicates a list which is started by a heading. If an indented dash (–) follows a dot, this list is subordinate to the dot.

Picture symbols



Regulation!

This picture symbol with the remark "Regulation" refers to a statutory regulation. Failure to comply with this regulation results in expiry of the type permit for the heater and preclusion of any guarantee and liability claims on J. Eberspächer GmbH & Co. KG.



Danger!

This picture symbol with the remark "Danger!" refers to the risk of a fatal danger to life and limb. Under certain circumstances, failure to comply with these instructions can result in severe or life-threatening injuries.



Caution!

This picture symbol with the remark "Caution!" refers to a dangerous situation for a person and/or the product. Failure to comply with these instructions can result in injuries to people and / or damage to machinery.

Please note!

These remarks contain application recommendations and useful tips for installation of the heater.

Important information before starting work

Range of application of the heater

The water heater operating independently of an engine is intended for installation in the following vehicles, depending on its heating output:

- Vehicles of all kinds
- Construction machinery
- Agricultural machinery
- Boats, ships and yachts

Please note!

Installation of the heater is permitted in vehicles used for the transport of dangerous goods as per ADR.

Purpose of the heater (using the vehicle heat exchanger)

- Pre-heating, de-misting windows
- Heating and keeping the following warm:
 - Driver and working cabs
 - Freight compartments
 - Ship's cabins
 - Passenger and crew compartments
 - Vehicle engines and units

On account of its functional purpose, the heater is **not** permitted for the following applications:

- Long-term continuous operation, e.g. for pre-heating and heating of:
 - Residential rooms
 - Garages
 - Work huts, weekend homes and hunting huts
 - Houseboats, etc.



Caution!

Safety instructions for application and proper purpose

The heater must only be used and operated for the range of application stated by the manufacturer in compliance with the "Operating instructions" included with every heater.



1 Introduction

Statutory regulations

The Federal Road Transport Directorate has issued an "EC type approval" and an "EMC type approval" for the heater for installation in motor vehicles and with the following official type approval marks, noted on the heater name plate.

HYDRONIC M-II EG-e1 00 0215

EMV-e1 035075



Regulation!

Directive 2001 / 56 / EU of the European Parliament and the Council

• Arrangement of the heater

- Parts of the structure and other components near the heater must be protected from excess heat exposure and possible contamination from fuel or oil.
- The heater must not pose a fire hazard even when it overheats.
This requirement is deemed to be fulfilled when adequate clearance to all parts is observed during installation, sufficient ventilation is provided and fire-proof materials or heat plates are used.
- The heater must not be located in the passenger compartment in vehicles of class M₁, M₂, M₃ and N. A unit may however be used in a hermetically sealed housing which also corresponds to the conditions stated above.
- The factory nameplate or duplicate must be affixed so that it can still be easily read when the heater is installed in the vehicle.
- All appropriate precautions must be taken when arranging the heater to minimise the risk of injuries to persons or damage to other property.

• Fuel supply

- The fuel intake connection must not be located in the passenger compartment and must be sealed with a properly closing lid to prevent any fuel leaks.
- In heaters for liquid fuel where the heater fuel is separate from the vehicle fuel, the type of fuel and intake connection must be clearly identified.
- A warning sign is to be fixed to the intake connection indicating that the heater must be switched off before refuelling.

• Exhaust system

- The exhaust outlet must be arranged so as to prevent any penetration of exhaust fumes into the vehicle interior through the ventilation system, warm air intakes or open windows.

• Combustion air intake

- The air for the heater combustion chamber must not be sucked in from the passenger compartment of the vehicle.
- The air intake must be arranged or protected in such a way that it cannot be blocked by other objects.

• Operating status display

- A clearly visible operating display in the user's field of vision must indicate when the heater is switched on and off.

1 Introduction

§ Regulations

Additional regulations for certain vehicles named in Directive 94 / 55 / EC (ADR Framework Directive)

Scope

This appendix applies to vehicles for which the special provisions of Directive 94 / 55 / EC apply to combustion heaters and their installation.

Definition of terms used

For the purposes of this appendix, the vehicle designations „EX / II“, „EX / III“, „AT“, „FL“ and „OX“ according to Chapter 9.1 of Annex B of Directive 94 / 55 / EC are used.

Technical regulations

General provisions (EX / II, EX / III, AT, FL and OX vehicles)

Avoid heating and ignition

The combustion heaters and their exhaust gas routing shall be designed, located, protected or covered so as to prevent any unacceptable risk of heating or ignition of the load. This requirement shall be considered as fulfilled if the fuel tank and the exhaust system of the appliance conform to provisions in 3.1.1.1 and 3.1.1.2. Compliance with these regulations shall be checked in the complete vehicle.

Fuel tanks

Fuel tanks for supplying the heater shall conform to the following regulations:

- In the event of any leakage, the fuel shall drain to the ground without coming into contact with hot parts of the vehicle or the load;
- fuel tanks containing petrol shall be equipped with an effective flame trap at the filler opening or with a closure enabling the opening to be kept hermetically sealed.

Exhaust system and exhaust pipe layout

The exhaust system as well as the exhaust pipes shall laid out or protected to avoid any danger to the load through heating or ignition. Parts of the exhaust system situated directly below the fuel tank (diesel) shall have a clearance of at least 100 mm or be protected by a thermal shield.

Switching on the combustion heater

The combustion heater may only be switched on manually. Automatic switching on via a programmable switch is not permitted.

EX / II and EX / III vehicles

Combustion heaters for gaseous fuels are not permitted.

FL vehicles

Combustion heaters must be able to be taken out of service/disabled at least by the methods described in the following:

- a) Switching off manually in the driver's cabin
- b) Switching off the vehicle's engine; in this case the heater may be manually switched back on by the vehicle driver;
- c) Starting up of a feed pump installed in the vehicle for the dangerous goods carried.

Combustion heater after-run

After-running of the switched off combustion heater is permitted. In the cases named in the „FL vehicles“ paragraph under letters b) and c) the supply of combustion air must be interrupted by suitable means after a maximum after-run period of 40 seconds. Only combustion heaters whose heat exchangers are verifiably not damaged by the reduced after-run period of 40 seconds beyond their usual use period may be used.

Please note!

- Compliance with the statutory regulations, the additional regulations and safety instructions is prerequisite for guarantee and liability claims.
Failure to comply with the statutory regulations and safety instructions and incorrect repairs even when using original spare parts make the guarantee null and void and preclude any liability for J. Eberspächer GmbH & Co. KG.
- Subsequent installation of this heater must comply with these installation instructions.
- The statutory regulations are binding and must also be observed in countries which do not have any special regulations.
- When the heater is to be installed in vehicles not subject to the German Ordinance for the Registration of Motor Vehicles (STVZO), for example ships, the specially valid regulations and installation instructions for these special applications must be observed.
- Installation of the heater in special vehicles must comply with the regulations applying to such vehicles.
- Other installation requirements are contained in the corresponding sections of this manual.



1 Introduction

Safety instructions for installation and operation



Danger!

Risk of injury, fire and poisoning

- Disconnect the vehicle battery before starting any kind of work.
- Before working on the heater, switch the heater off and let all hot components cool down.
- The heater must not be operated in enclosed rooms, e.g. in the garage or multi-storey car park.



Caution!

Safety instructions for installation and operation

- The heater must only be installed by a JE partner authorised by the manufacturer according to the instructions in this manual and possibly according to special installation recommendations; the same applies to any repairs to be carried out in the case of repairs or guarantee claims.
- Repairs by non-authorised third-parties or with not original spare parts are dangerous and therefore not allowed. They result in expiry of the type permit of the heater; consequently, when installed in motor vehicles they can cause expiry of the vehicle operating licence.
- The following measures are not allowed:
 - Changes to components relevant to the heater.
 - Use of third-party components not approved by J. Eberspächer GmbH & Co. KG.
 - Nonconformities in installation or operation from the statutory regulations, safety instructions or specifications relevant to safe operation as stated in the installation instructions and operating instructions. This applies in particular to the electrical wiring, fuel supply, combustion air system and exhaust system.
- Only original accessories and original spare parts must be used during installation or repairs.
- Only original accessories and spare parts may be used for installation or repairs.
- Only the controls approved by Eberspächer may be used to operate the heater. The use of other controls can result in malfunctions.
- Before the heater is installed again in another vehicle, rinse the heater parts carrying water with clear water.
- When carrying out electric welding on the vehicle, the plus pole cable at the battery should be disconnected and placed at ground to protect the controller.

- The heater must not be operated where there is a risk of an accumulation of flammable vapours or dust, for example close to
 - fuel depot
 - coal depot
 - wood depot
 - grain depots etc.
- The heater must be switched off when refuelling.
- When the heater is mounted in a safety housing etc., the installation compartment of the heater is not a stowage compartment and must be kept clear. In particular fuel canisters, oil cans, spray cans, gas cartridges, fire extinguishers, cleaning rags, items of clothing, paper etc. must not be stored or transported on or next to the heater.
- Defect fuses must only be replaced by fuses with the prescribed rating.
- If fuel leaks from the heater fuel system, arrange for the damage to be repaired immediately by a JE service partner.
- When topping up the coolant, only use the coolant permitted by the vehicle manufacturer, see the vehicle operating manual. Any blending with unpermitted coolant can cause damage to the engine and heater.
- After-running of the heater must not be interrupted prematurely e.g. by pressing the battery disconnecting switch, apart from in the case of an emergency stop.

Accident prevention

General accident prevention regulations and the corresponding workshop and operation safety instructions are to be observed.

2 Product information

Scope of supply

Quantity / Designation	Order number
1 HYDRONIC M8 Biodiesel	
12 Volt	25 2470 05 00 00
24 Volt	25 2471 05 00 00
To be ordered separately:	
1 Universal installation kit	25 2435 80 00 00
1 Control unit*	–
1 HYDRONIC M10	
12 Volt	25 2434 05 00 00
24 Volt	25 2435 05 00 00
To be ordered separately:	
1 Universal installation kit	25 2435 80 00 00
1 Control unit*	–
1 HYDRONIC M12	
12 Volt	25 2472 05 00 00
24 Volt	25 2473 05 00 00
To be ordered separately:	
1 Universal installation kit	25 2435 80 00 00
1 Control unit*	–

* Control units see price list / accessories catalogue..

Please note!

- The cable harness, Order No. 25 2435 80 06 00, is also required for vehicles used for transporting dangerous goods.
- Please consult the additional parts catalogue if any other parts are required for installation.

Parts list for the „Scope of supply“ figure on page 9

HYDRONIC M8 Biodiesel heater scope of supply

Picture-No.	Designation
1	Heater
2	Metering pump
21	Tube, Ø 6 x 1, length 6 m
22	Transition piece Ø 3.5 / 5, (2 x)
–	Hose clamp Ø 10, (4 x)

HYDRONIC M10 / M12 heater scope of supply

Picture-No.	Designation
1	Heater
2	Metering pump

Universal installation kit scope of supply

Picture-No.	Designation
3	Relay 12 V / 24 V
4	Exhaust silencer
5	Cable tree, heater
6	Bracket, heater
7	Flexible exhaust pipe
8	Cable ties (10 x)
9	Pipe, Ø 6 x 1, length 1,5 m
10	Hose, Ø 5 x 3, length 0,5 m
11	Pipe, Ø 4 x 1, length 6 m
12	Hose, Ø 3,5 x 3, length 10 cm
13	Intake silencer for combustion air
14	Water hose
15	Water hose
16	Lead harness, metering pump
17	Lead harness, blower
18	Corrugated tube, Inner Ø 10 mm, length 2 m
19	Grommet
20	Bracket
–	Small parts

Cable harnesses

- A „Controls“ lead harness
- B „Blower control“ lead harness
- C Positive cable
- D Negative cable
- E Connection, blower relay positive supply cable at the fuse holder
- F Connection at blower relay, terminal 85 (1-pole, brown)
- G Connection at blower relay, terminal 86 (1-pole, red/yellow)
- H Metering pump connection



2 Product information

Scope of supply

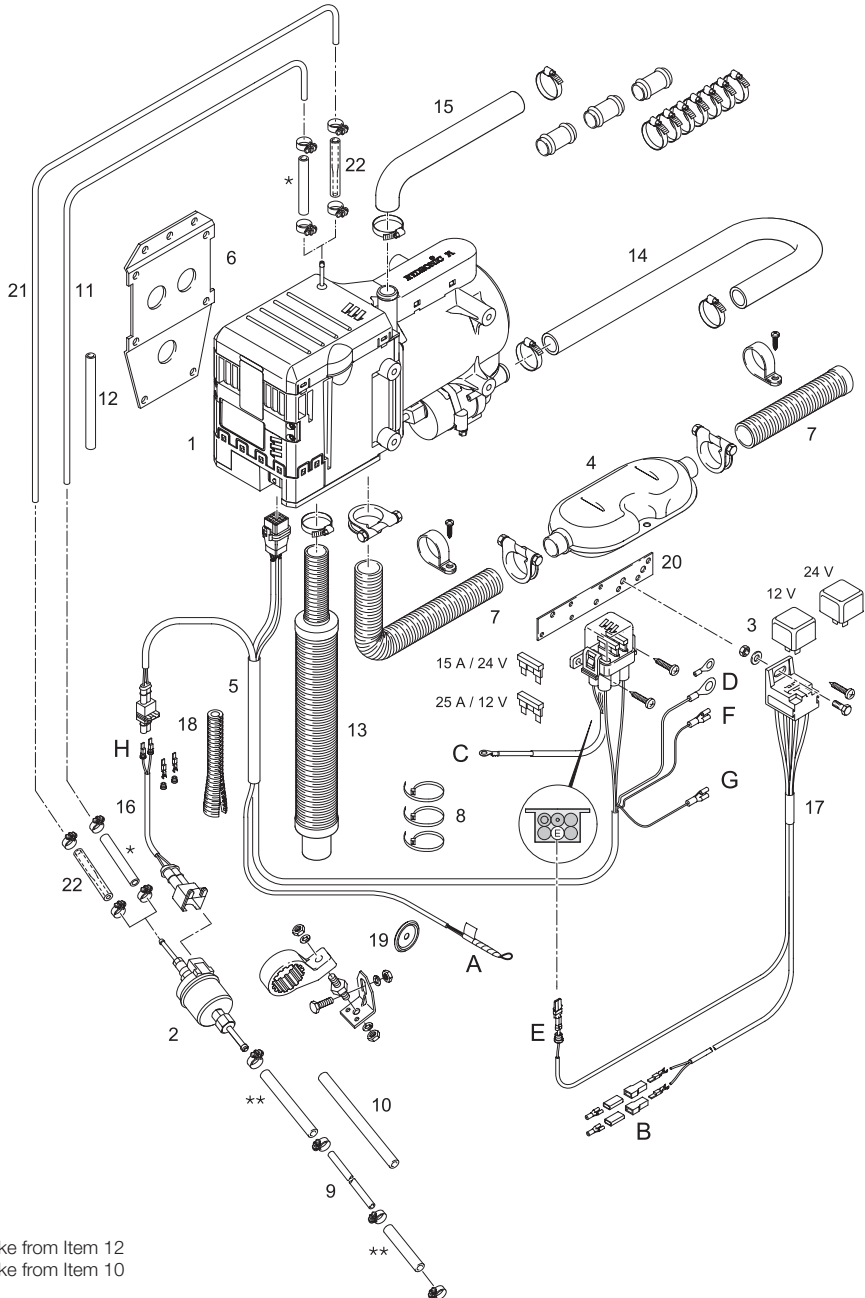

* make from Item 12
** make from Item 10

2 Product information

Technical data

Heater type	HYDRONIC M-II			
Heater	HYDRONIC M8 Biodiesel			
Version	D 8 W			
Heating medium	Mixture of water and coolant (max. 50 % water, 50 % coolant)			
Control of the heat flow	Power	Large	Medium	Small
Heat flow (watt) Figures for operation with diesel fuel. If operated with FAME the heat flow can reduce by up to 15 %.	8000	5000	3500	1500
Fuel consumption (l/h)	0.90	0.65	0.40	0.18
Electrical power (watt)	in operation			
	55	46	39	35
	at start – after 25 Sek.			
	200			
	in the control phase "OFF"			
	32			
Rated voltage	12 Volt		24 Volt	
Operating range	10 Volt		20 Volt	
<ul style="list-style-type: none"> Lower voltage limit: An undervoltage protection in the controller switches the heater off on reaching the voltage limit. 				
<ul style="list-style-type: none"> Upper voltage limit: An overvoltage protection in the controller switches the heater off on reaching the voltage limit. 	15 Volt		30 Volt	
Tolerable operating pressure	up to 2 bar overpressure			
Flow rate of the water pump at 0.14 bar	1400 l/h			
Minimum water flow rate of the heater	500 l/h			
Fuel – see also "Fuel quality diesel heaters" page 27	Commercially available diesel (DIN EN 590) FAME – for diesel engines according to DIN EN 14 214			
Tolerable operating temperature	Operation		Not running	
Heater / Control box	Diesel	–40 °C to +80 °C		–40 °C to +85 °C
	FAME	–8 °C to +80 °C		–40 °C to +85 °C
Dosing pump	Diesel	–40 °C to +50 °C		–40 °C to +85 °C
	FAME	–8 °C to +50 °C		–40 °C to +85 °C
Interference suppression class	interference suppression class 5 to DIN EN 55 025			
Weight with controller and water pump, without dosing pump	approx. 6.2 kg			



Caution!

Safety instructions for technical data

Failure to comply with the technical data can result in malfunctions.

Please note!

Provided no limit values are given, the technical data listed is subject to the tolerances usually applicable to heaters of $\pm 10\%$ for nominal voltage, ambient temperature 20 °C and reference altitude Esslingen.



2 Product information

Technical data

Heater type	HYDRONIC M-II				
Heater	HYDRONIC M10				
Version	D 10 W				
Heating medium	Mixture of water and coolant (max. 50 % water, 50 % coolant)				
Control of the heat flow	Power	Large	Medium	Small	
Heat flow (watt)	9500	8000	3500	1500	
Fuel consumption (l/h)	1.2	0.9	0.4	0.18	
Electrical power (watt)/V	in operation	86	60	39	35
	at start – after 25 Sek.	120			
	in the control phase “OFF”	32			
Rated voltage	12 Volt		24 Volt		
Operating range	10 Volt		20 Volt		
	15 Volt		30 Volt		
<ul style="list-style-type: none"> • Lower voltage limit: An undervoltage protection in the controller switches the heater off on reaching the voltage limit. • Upper voltage limit: An overvoltage protection in the controller switches the heater off on reaching the voltage limit. 					
Tolerable operating pressure	up to 2 bar overpressure				
Flow rate of the water pump at 0.14 bar	1400 l/h				
Minimum water flow rate of the heater	500 l/h				
Fuel – see also “Fuel quality diesel heaters” page 27	Commercially available diesel (DIN EN 590)				
Tolerable operating temperature	Operation		Not running		
	Heater / Control box		–40 °C to +85 °C		
	Dosing pump		–40 °C to +85 °C		
Interference suppression class	interference suppression class 5 to DIN EN 55 025				
Weight with controller and water pump, without dosing pump	approx. 6.2 kg				



Caution!

Safety instructions for technical data

Failure to comply with the technical data can result in malfunctions.

Please note!

Provided no limit values are given, the technical data listed is subject to the tolerances usually applicable to heaters of $\pm 10\%$ for nominal voltage, ambient temperature 20 °C and reference altitude Esslingen.

2 Product information

Technical data

Heater type	HYDRONIC M-II						
Heater	HYDRONIC M12						
Version	D 12 W						
Heating medium	Mixture of water and coolant (max. 50 % water, 50 % coolant)						
Control of the heat flow	Power	Large	Medium 1	Medium 2	Medium 3	Small	
Heat flow (watt)	12000	9500	5000	3500	1500	1200	
Fuel consumption (l/h)	1.5	1.2	0.65	0.40	0.18	0.15	
Electrical power (watt)(l)	in operation	132	86	46	39	35	34
	at start – after 25 Sek.	120					
	in the control phase "OFF"	32					
Rated voltage	12 Volt			24 Volt			
Operating range	10 Volt			20 Volt			
<ul style="list-style-type: none"> Lower voltage limit: An undervoltage protection in the controller switches the heater off on reaching the voltage limit. 							
<ul style="list-style-type: none"> Upper voltage limit: An overvoltage protection in the controller switches the heater off on reaching the voltage limit. 	15 Volt			30 Volt			
Tolerable operating pressure	up to 2 bar overpressure						
Flow rate of the water pump at 0.14 bar	1400 l/h						
Minimum water flow rate of the heater	500 l/h						
Fuel – see also "Fuel quality diesel heaters" page 27	Commercially available diesel (DIN EN 590)						
Tolerable operating temperature	Operation			Not running			
	Heater / Control box						
	–40 °C to +80 °C			–40 °C to +85 °C			
Dosing pump							
–40 °C to +50 °C			–40 °C to +85 °C				
Interference suppression class	interference suppression class 5 to DIN EN 55 025						
Weight with controller and water pump, without dosing pump	approx. 6.2 kg						



Caution!

Safety instructions for technical data

Failure to comply with the technical data can result in malfunctions.

Please note!

Provided no limit values are given, the technical data listed is subject to the tolerances usually applicable to heaters of $\pm 10\%$ for nominal voltage, ambient temperature 20 °C and reference altitude Esslingen.



2 Product information

Main dimensions

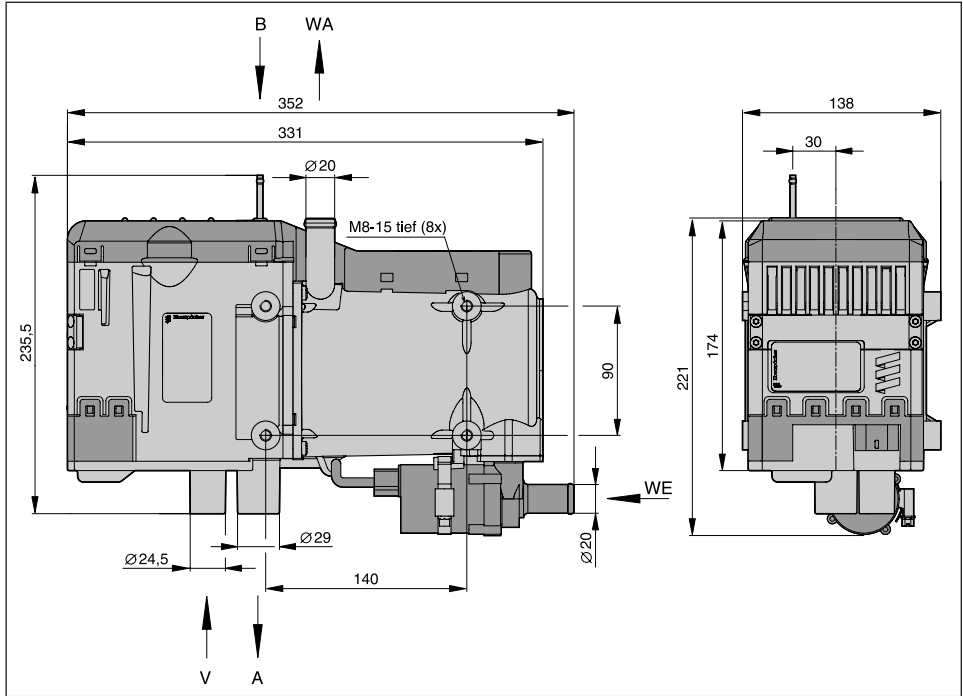

- A Exhaust
- B Fuel
- V Combustion air
- WA Water outlet
- WE Water inlet

3 Installation

Installation location

The installation location for the heater is the engine compartment. The heater must be mounted below the min. cooling water level (compensation tank, cooler, vehicle heat exchanger) for automatic venting of the heat exchanger of the heater and the water pump.

Please note!

- In a truck, the water heater is preferably fastened underneath the driver's cab in the longitudinal beam near the vehicle engine.
- The regulations and safety instructions to be observed for this chapter are stated on page 4 – 7.
- The installation suggestions made in the installation instructions are examples. Other installation locations are possible if they correspond to the installation requirements stated in these installation instructions.
- Other installation information (e.g. for boats and ships) is available from the manufacturer on request.
- Please take note of the installation locations together with the operating and storage temperatures.

Installation example heater in a truck

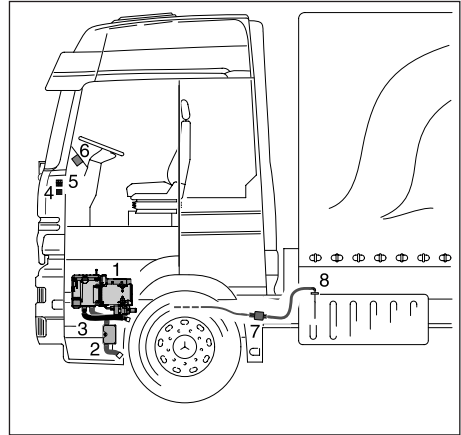

- 1 Heater
- 2 Exhaust pipe with exhaust silencer
- 3 Combustion air intake silencer
- 4 Fan relay
- 5 Fuse bracket
- 6 Controls
- 7 Dosing pump
- 8 Tank connection

Installing the 24 V heater in a vehicle for the transport of dangerous goods as per ADR

For installation of the heater in vehicles for the transport of dangerous goods, the regulations of ADR / ADR99 must be observed.

With the appropriate electrical wiring the heater fulfils the ADR regulations, see the "Additional Regulations" on Page 6, the "Control and Safety Devices" on Page 29 and the "Circuit Diagrams" on Page 34 and 39.

Detailed information about the ADR regulations is contained in leaflet no. 25 2161 95 15 80.



3 Installation

Possible installation positions

The heater should preferably be installed in the normal position, horizontal with the exhaust connection down to the bottom.

Depending on the installation conditions, the heater can also be mounted in the permitted swivel range, see diagram.

When the heater is operating, the shown normal or maximum installation positions can be varied briefly by up to $+15^\circ$ in all directions. Such deviations caused by the inclined position of the vehicle do not impair the heater functions in any way.

Normal position with permitted swivel range

- Swivel range from the normal position swivelled up to max. 85° downward – the heater's water outlet socket is horizontal. The water pump's water inlet socket must face downward.
- Swivel range from the normal position swivelled up to max. 90° to the left about the longitudinal axis – the water outlet socket is at the top of the heater and faces the left.

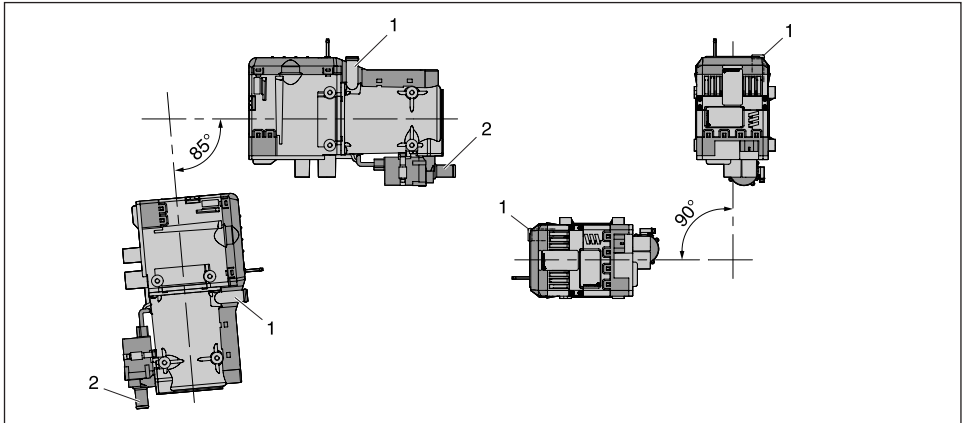

- 1 Water outlet socket, heater
2 Water inlet socket, water pump

Mounting and fastening

Fix the unit holder from the installation kit to the heater using 4 hexagon screws M8 and 4 spring washers (tightening torque $12^{+0.5}$ Nm).

Fix the heater and the mounted unit holder in a suitable place in the vehicle using 5 hexagon screws M8, 5 spring washers and 5 hexagon nuts M8 (tightening torque $12^{+0.5}$ Nm).

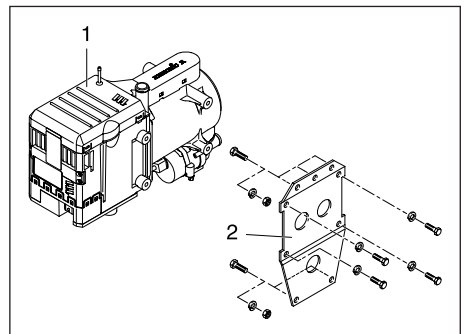

- 1 Heater
2 Heater bracket

3 Installation

Nameplate

The nameplate is on the front and the 2nd nameplate (duplicate) is fixed to the side of the control box / fan unit.

If required, the installer can stick the duplicate nameplate in a clearly visible position elsewhere on the heater or near to the heater.

Please note!

The regulations and safety instructions to be observed for this chapter are stated on page 5.

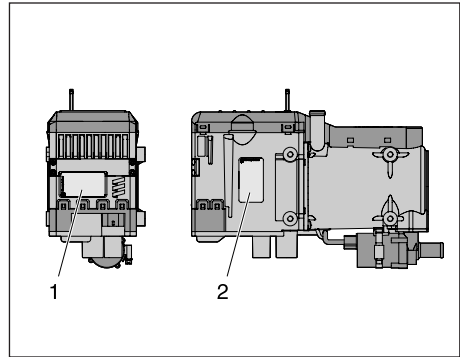

- 1 Original nameplate
- 2 2nd nameplate (duplicate)



3 Installation

Connection to the cooling water circuit

The heater is connected to the cooling water circuit in the water feed pipe from the vehicle engine to the heat exchanger. There are three possible alternative installations here.

The alternatives are described on pages 16 – 18.



Danger!

Risk of injuries and burns!

It is possible for the coolant and components of the coolant circuit to get very hot.

- Parts conveying water must be routed and fastened in such a way that they pose no temperature risk to man, animals or material sensitive to temperature from radiation / direct contact.
- Before working on the coolant circuit, switch the heater off and wait until all components have cooled down completely, if necessary where safety gloves.

Please note!

- When installing the heater, please take note of the direction of flow of the coolant circuit.
- Fill the heater and water hoses with coolant before connecting to the coolant circuit.
- Route the water hoses without any kinks, and in a rising position if possible.
- When routing the water pipes, observe a sufficient clearance to hot vehicle parts.
- Protect all water hoses / water pipes from chafing and from extreme temperatures.
- Secure all hose connections with hose clips. (tightening torque = 1.5 Nm)
- After the vehicle has been operating for 2 hours or travelled 100 km, tighten the hose clips again.
- The minimum water flow rate is only guaranteed if the temperature difference of the heating medium does not exceed 15 K between water inlet and water outlet during heating.
- Only overpressure valves with an opening pressure of min. 0.4 – max. 2 bar may be used in the coolant circuit.
- The coolant liquid must contain at least 10 % antifreeze all year round as corrosion protection.
- The cooling liquid must contain sufficient antifreeze for low temperatures.
- Before commissioning the heater or after changing the cooling liquid, the whole coolant circuit including heater must be vented free of bubbles according to the instructions issued by the vehicle manufacturer.
- Only top up with coolant approved by the vehicle manufacturer.

3 Installation

Connection to the cooling water circuit

Integrate the heater with non-return valve in the coolant circuit

Disconnect the water feed pipe from the vehicle engine to the vehicle heat exchanger and insert the non-return valve. Connect the heater with its water pipes to the non-return valve.

Advantage:

Simple installation.

Disadvantage:

The coolant flows through the vehicle engine constantly so that in large vehicle engines, adequate cab heating is scarcely possible.

Heating characteristics:

When the heater is switched on, the heat flows through the vehicle heat exchanger and the vehicle engine. Once the cooling water has reached a temperature of approx. 55 °C, depending on the selected fan setting the vehicle fan is switched on and the heat is also conveyed to the passenger compartment.

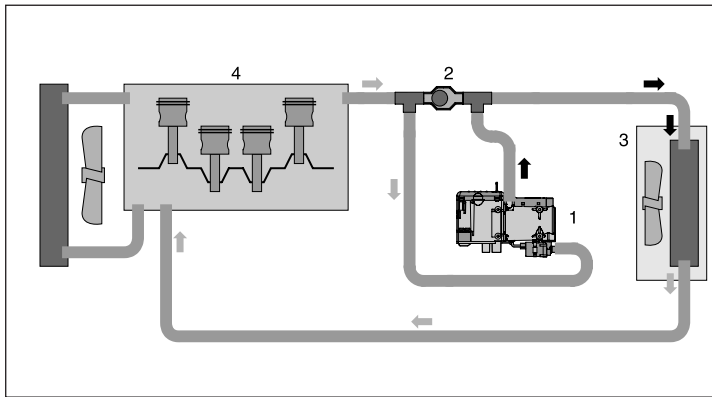

- 1 Heater
- 2 Non-return valve
- 3 Heat exchanger
- 4 Vehicle engine

Please note!

Non-return valve must be ordered separately, see additional parts catalogue for Order No.



3 Installation

Connection to the coolant circuit

Integrate the heater with non-return valve, thermostat and T-piece in the coolant circuit

Disconnect the water feed pipe from the vehicle engine to the vehicle heat exchanger and insert the non-return valve.

Disconnect the water return pipe from the heat exchanger to the vehicle engine and insert the T-piece.

Connect the heater and thermostat with water hoses to the non-return valve and T-piece as shown in the diagram.

Option:

In addition a solenoid can be fitted in the water circuit. When open, this bypasses the thermostat and pre-heats the engine as soon as the heater starts to work.

Heating characteristics

• Small coolant circuit: fast heating of the passenger compartment

Initially the heat produced by the heater is only conveyed to the vehicle heat exchanger up to a cooling water temperature of approx. 70 °C.

The vehicle fan switches on at approx. 55 °C.

• Large cooling water circuit: heating of the passenger compartment and additional engine pre-heating

If the cooling water temperature continues to increase, the thermostat slowly changes over to the large circuit (full change-over at approx. 75 °C).

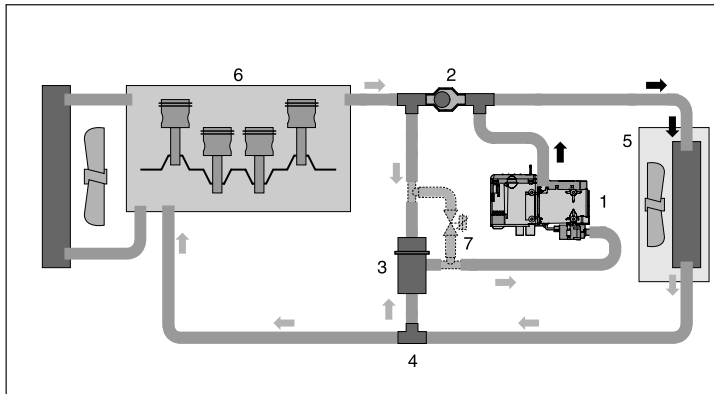

- 1 Heater
- 2 Non-return valve
- 3 Thermostat
- 4 T-piece
- 5 Heat exchanger
- 6 Vehicle engine
- 7 Solenoid (option)

Please note!

The thermostat, non-return valve and T-piece must be ordered separately, see additional parts catalogue for Order No.

The solenoid valve has to be purchased through the trade.

Thermostat functions

Small coolant circuit

Cooling water temperature < 70 °C:

Connection no. 1: open to the heater

Connection no. 2: open to the T-piece

Connection no. 3: closed to the non-return valve

Large coolant circuit

Cooling water temperature > 75 °C:

Connection no. 1: open to the heater

Connection no. 2: closed to the T-piece

Connection no. 3: open to the non-return valve

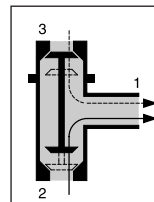

- 1 Connection to the heater
- 2 Connection to the T-piece
- 3 Connection to the non-return valve

Please note!

Integrate the thermostat into the water circuit with connections (1) (2) and (3) as shown in the diagram.

3 Installation

Connection to the coolant circuit

Integrate the heater with a solenoid in the coolant circuit

Disconnect the water flow hose from the vehicle's engine to the vehicle's heat exchanger and insert two T-pieces. Connect the T-pieces with a hose.

Disconnect the water return pipe from the heat exchanger to the vehicle engine and insert the solenoid. Connect the heater and the solenoid to the T-piece with water pipes, as shown in the diagram.

Option:

In addition, a non-return valve with connection hoses between the two T-pieces can be inserted in the cooling water circuit.

This prevents the loss of effective vehicle heating when the heater is switched off.

Heating characteristics

By installing the electric solenoid valve, temperature-independent choice between the small cooling water circuit (driver's cab) and large cooling water circuit (vehicle engine with driver's cab) is possible.

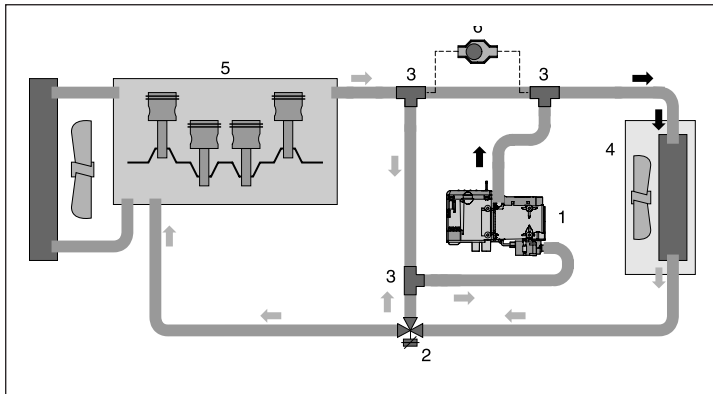

- 1 Heater
- 2 Solenoid
- 3 T-piece
- 4 Heat exchanger
- 5 Vehicle engine
- 6 Non-return valve (option)

Please note!

The T-pieces and non-return valve must be ordered separately. For Order No., see additional parts catalogue. The solenoid valve has to be purchased through the trade.



3 Installation

Exhaust system

(Exhaust diagram see page 22)

Mounting the exhaust system

The universal installation kit includes a flexible exhaust pipe, inner \varnothing 30 mm, 1300 mm long and an exhaust silencer.

The flexible exhaust pipe can be shortened to 20 cm or lengthened to max. 2 m, depending on the installation conditions.

Fasten the exhaust silencer to a suitable position in the vehicle.

Route the flexible exhaust pipe from the heater to the exhaust silencer and fasten with pipe clips.

If necessary, also fasten the flexible exhaust pipe with pipe clips at suitable positions in the vehicle.

Connect the exhaust end pipe to the exhaust silencer with an end sleeve and fasten with a pipe clip.



Danger!

Risk of injuries and burns!

Every type of combustion produces high temperatures and toxic exhaust fumes. This is the reason why the exhaust system must be installed according to these instructions.

- Do not perform any work on the exhaust system while the heater is working.
- Before working on the exhaust system, first switch the heater off and wait until all parts have cooled down completely, wear safety gloves if necessary.
- Do not inhale exhaust fumes.



Caution!

Safety instructions for the exhaust system!

- The exhaust outlet must end in the open air.
- The exhaust pipe must not protrude beyond the lateral limits of the vehicle.
- Install the exhaust pipe sloping slightly downwards. If necessary, make a drain hole approx. \varnothing 5 mm at the lowest point to drain off condensation.
- Important functional parts of the vehicle must not be impaired (keep sufficient clearance).
- Mount the exhaust pipe with sufficient clearance to heat-sensitive parts. Pay particular attention to fuel pipes (plastic or metal), electrical cables and brake hoses etc.!
- Exhaust pipes must be fastened safely (recommended clearance of 50 cm) to avoid damage from vibrations.
- Route the exhaust system so that the emitted fumes are not sucked in with the combustion air.
- The mouth of the exhaust pipe must not get clogged by dirt and snow.
- The mouth of the exhaust pipe must not point in the direction of travel.
- Always fasten the exhaust silencer to the vehicle.

Please note!

- Comply with the regulations and safety instructions for this chapter on page 4 – 7.
- The exhaust end pipe should be much shorter than the flexible exhaust pipe from the heater to the exhaust silencer.

3 Installation

Combustion air system

Mounting the combustion air system

The universal installation kit includes an intake silencer, inner \varnothing 25 mm for the combustion air.

The intake silencer must be installed and, if necessary, can be extended by up to 2 m max using a flexible pipe (inner \varnothing 25 mm) and a connection pipe (outer \varnothing 24 mm) – not included in the scope of supply.

Fasten the intake silencer and where applicable the flexible pipe at suitable points in the vehicle using fastening clips and cable ties.

Please note!

- Comply with the regulations and safety instructions for this chapter on page 4 – 7.
- Order no. flexible pipe see extra parts catalogue.
- Extension of the intake silencer is not permitted for mainly operation at high altitudes (over 1200 m).



Caution!

Safety instructions for the combustion air system!

- The combustion air opening must be free at all times.
- Position the combustion air intake to be sure that exhaust fumes cannot be sucked in with the combustion air.
- The combustion air intake must not get clogged with dirt and snow.
- Install the combustion air intake system sloping slightly downwards.
- If necessary, make a drain hole approx. \varnothing 5 mm at the lowest point to drain off condensation.
- When routing the intake silencer and flexible pipe, avoid narrow bends.

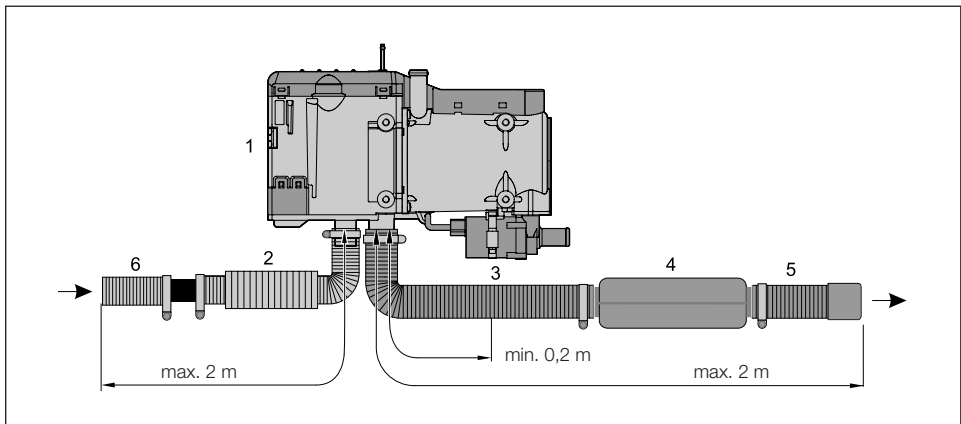

- 1 Heater
- 2 Intake silencer for the combustion air
- 3 Flexible exhaust pipe
- 4 Exhaust silencer
- 5 Flexible exhaust end pipe with end sleeve
- 6 Extension of the intake silencer; is not included in the scope of supply. Not allowed for mainly heating mode at high altitudes (over 1200 m).



3 Installation

Fuel supply

Mounting the dosing pump, routing the fuel pipes and mounting the fuel tank

The following safety instructions must be observed when mounting the dosing pump, routing the fuel pipes and mounting the fuel tank.

Deviations from the instructions stated here are not allowed.

Failure to comply can result in malfunctions.



Danger!

Risk of fire, explosion, poisoning and injuries!

Caution when handling fuel.

- Switch off the vehicle engine and heater before refueling and before working on the fuel supply.
- No naked lights when handling fuel.
- Do not smoke.
- Do not inhale fuel vapours.
- Avoid any contact with the skin.



Caution!

Safety instructions for routing the fuel pipes!

- Only use a sharp knife to cut off fuel hoses and pipes. Interfaces must not be crushed and must be free of burrs.
- The fuel pipe from the dosing pump to the heater should be routed at a continuous rise.
- Fuel pipes must be fastened safely to avoid any damage and / or noise production from vibrations (recommended clearance of approx. 50 cm).
- Fuel pipes must be protected from any mechanical damage.
- Route the fuel pipes so that any distortion of the vehicle, engine movements etc. cannot have any lasting effect on the service life.

- Parts carrying fuel must be protected from interfering heat.
- Never route or fasten the fuel pipes to the heater or vehicle exhaust system. When the systems cross, always ensure there is a sufficient heat clearance. If necessary, install heat deflection plates.
- Dripping or evaporating fuel must never be allowed to collect on hot parts or ignite on electric systems.
- When connecting fuel pipes with a fuel hose, always mount the fuel pipes in a butt joint to prevent any bubbles from forming.

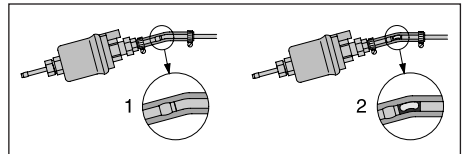

- 1 Correct connection
- 2 Incorrect connection – bubble formation

Safety instructions for fuel pipes and fuel tanks in buses and coaches

- In buses and coaches, fuel pipes and fuel tanks must not be routed through the passenger compartment or driver's cab.
- Fuel tanks in buses and coaches must be positioned in such a way that the exits are not in direct danger from a possible fire.

Please note!

Comply with the regulations and safety instructions for this chapter on page 4 – 7.

3 Installation

Fuel supply

Fuel feed point with T-piece from the fuel supply line from the tank fitting to the vehicle engine

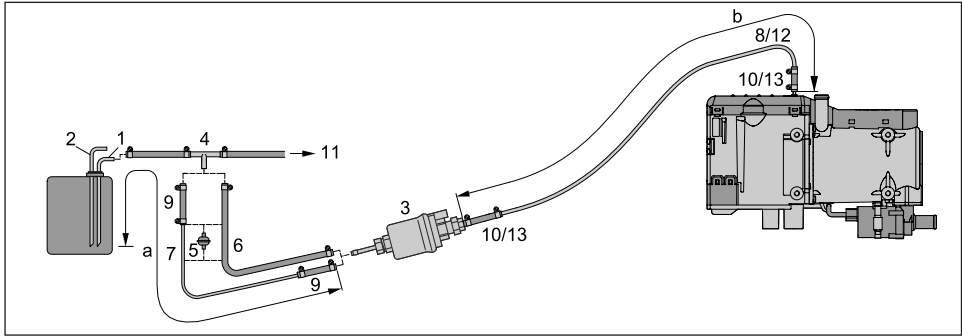

- 1 Fuel feed pipe from tank connection
- 2 Fuel return pipe to the tank connection
- 3 Dosing pump
- 4 T-piece
- 5 Fuel filter
- 6 Fuel hose, 5 x 3 (di = Ø 5 mm)
- 7 Fuel pipe, 6 x 1 (di = Ø 4 mm)
- 8 Fuel pipe, 4 x 1 (di = Ø 2 mm)
- 9 Fuel hose, 5 x 3 (di = Ø 5 mm), approx. 50 mm long
- 10 Fuel hose, 3,5 x 3 (di = Ø 3,5 mm), approx. 50 mm long
- 11 To the engine, mechanical fuel or injection pump.

Required for *HYDRONIC M8* biodiesel for operation with FAME only.

- 12 Fuel pipe blue, 6 x 1 (di = Ø 4 mm)
- 13 Transition piece 3,5 / 5

Possible pipe lengths

Intake side
a = max. 2 m

Pressure side
b = min. 1.5 m – max. 6 m

Please note!

- Insert the T-piece (4) in the fuel flow line upstream of the feed pump. T-piece is not included in the “installation kit” scope of supply. The order no. is given in the additional parts catalogue.
- Fuel filter, Item (5), is required for contaminated fuel only. Fuel filter is not included in the “installation kit” scope of supply. The order no. is given in the additional parts catalogue.
- Items (12) and (13) are only included in the “*HYDRONIC M8 Biodiesel*” heater’s scope of supply.

Installation position of the T-piece

Use the installation positions shown in the diagram when inserting a T-piece.

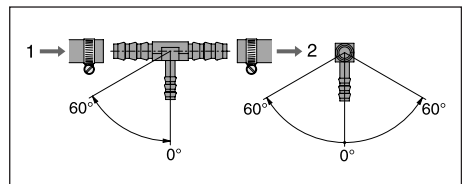

- 1 Direction of flow from the fuel tank
- 2 Direction of flow to the vehicle engine



3 Installation

Fuel supply

Fuel feed point with tank connection – ascending pipe, integrated in the vehicle tank

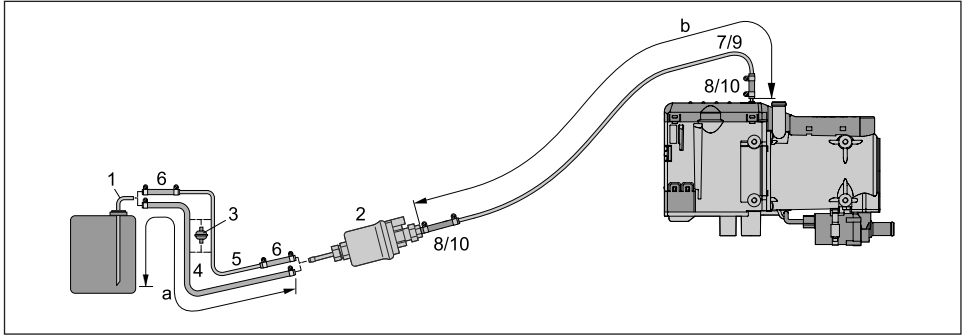

- 1 Tank connection for metal tank –
di = Ø 4 mm, da = Ø 6 mm
- 2 Dosing pump
- 3 Fuel filter
- 4 Fuel hose, 5 x 3 (di = Ø5 mm)
- 5 Fuel pipe, 6 x 1 (di = Ø 4 mm)
- 6 Fuel hose, 5 x 3 (di = Ø 5 mm), approx. 50 mm long
- 7 Fuel pipe, 4 x 1 (di = Ø 2 mm)
- 8 Fuel hose, 3,5 x 3 (di = Ø 3.5 mm), approx. 50 mm long

Required for *HYDRONIC* M8 biodiesel for operation with FAME only.

- 9 Fuel pipe blue, 6 x 1 (di = Ø 4 mm)
- 10 Transition piece 3,5 / 5

Possible pipe lengths

Intake side
a = max. 2 m

Pressure side
b = min. 1.5 m – max. 6 m

Please note!

- Item (1), tank connection for metal tank, is not included in the scope of supply "installation kit". Order no. see extra parts catalogue.
- Fuel filter, Item (3), is required for contaminated fuel only. Fuel filter is not included in the "installation kit" scope of supply. The order no. is given in the additional parts catalogue.
- Items (9) and (10) are only included in the "*HYDRONIC* M8 Biodiesel" heater's scope of supply.
- When installing tank connection maintain a minimum distance of 50 ± 2 mm from the end of the riser pipe and the bottom of the tank.



Caution!

Safety instructions for the fuel supply!

- The fuel must not be conveyed by gravity or overpressure in the fuel tank.
- Withdrawal of fuel after the vehicle's fuel pump is not allowed.
- When the pressure in the fuel pipe is more than 4.0 bar or there is a non-return valve in the return pipe (in the tank), a separate tank connection must be used.
- When using a T-piece in a plastic pipe, always use support sleeves in the plastic. Connect the T-piece and the plastic pipe with corresponding fuel hoses and secure with hose clips.

3 Installation

Fuel supply

Installation position of the dosing pump

Always mount the dosing pump with the pressure side rising upwards. Every installation position over 15° is allowed, although an installation position between 15° and 35° is preferable.

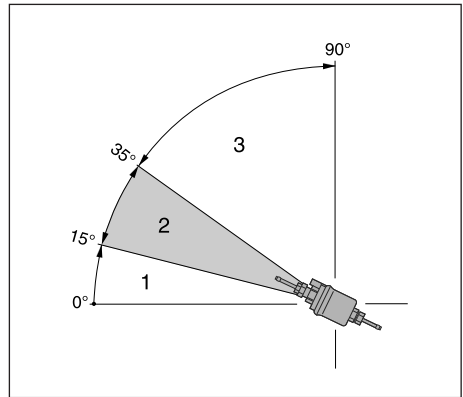

- 1 Installation position between 0° and 15° is not allowed.
- 2 Preferred installation position in range 15° to 35°.
- 3 Installation position in range 35° to 90° is allowed.

Possible intake and pressure height of the dosing pump

Pressure height from vehicle tank to dosing pump:
a = max. 1000 mm

Intake height for non-pressurised vehicle tank:
b = max. 750 mm

Intake height for a vehicle tank with withdrawal by negative pressure (valve with 0.03 bar in the tank lid):
= max. 400 mm

Pressure height from the dosing pump to the heater:
c = max. 2000 mm

Please note!

Check tank venting.

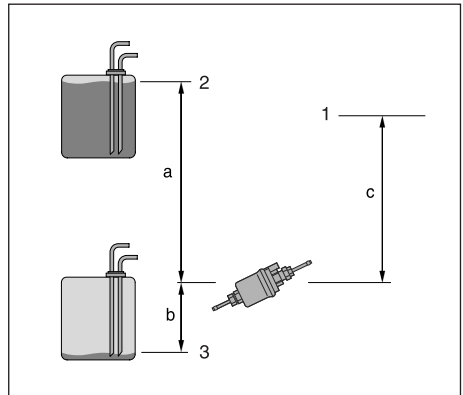

- 1 Connection to heater
- 2 Max. fuel level
- 3 Min. fuel level



Caution!

Safety instructions for installing the dosing pump

- Always mount the dosing pump with the pressure side rising upwards – minimum incline 15°.
- Protect the dosing pump and filter from intolerable heat, do not mount near to the silencers and exhaust pipes.



3 Installation

Fuel supply

Fuel quality

- The heater runs without problems on normal commercial diesel fuel according to DIN EN 590.
During the winter months the diesel fuel is adapted to low temperatures from 0 °C to -20 °C. Problems can therefore only arise if outdoor temperatures are extremely low – which also applies to the vehicle's engine – please refer to the vehicle manufacturer's regulations.
- In special cases and at outdoor temperatures above 0 °C the heater can also be run on heating oil EL according to DIN 51603.
- If the heater is run from a separate tank, please comply with the following rules:
 - If outdoor temperatures over 0 °C:
Use diesel fuel according to DIN EN 590.
 - If outdoor temperatures from 0 °C to -20 °C:
Use winter diesel fuel according to DIN 590.
 - If outdoor temperatures -20 °C to -40 °C:
Use Arctic Diesel or Polar Diesel.

Please note!

- It is **not** permitted to add used oil!
- After refuelling with winter or cold diesel or the listed blends, the fuel pipes and the dosing pump must be filled with the new fuel by letting the heater run for 15 mins!

Operation with biodiesel (FAME for diesel engines according to DIN EN 14 214)

HYDRONIC M8 Biodiesel

The heater is approved for operation with biodiesel up to a temperature of -8°C (the flowability reduces at temperatures below 0 °C).

Please note!

- When using 100 % biodiesel, the heater should be run on diesel fuel twice a year (in the middle and at the end of a heating period) to burn off possibly accumulated biodiesel deposits. To do so, let the vehicle tank run almost empty and fill with diesel fuel without adding any biodiesel. While running on this tank filling, switch the heater on 2 to 3 times for 30 minutes at a time at the highest temperature setting.
- If constantly operated with diesel / biodiesel mixtures of up to 50 % biodiesel, intermediate operation with pure diesel fuel is not necessary.

HYDRONIC M10 / HYDRONIC M12

Both heaters are **not** approved for operation with biodiesel.
Up to 10 % biodiesel may be added.

4 Operation and function

Operating instructions

The heater is operated by a control unit. The control unit is accompanied by detailed operating instructions which you will receive from the company installing the heater.

Initial commissioning

The following points are to be checked by the company installing the heater during initial commissioning.

- After installation of the heater, the coolant circuit and the whole fuel supply system must be vented carefully. Comply with the instructions issued by the vehicle manufacturer.
- Open the coolant circuit before the trial run (set the temperature control to "WARM").
- During the trial run of the heater, check all water and fuel connections for leaks and firm fitting.
- If the heater shows a fault during operation, find and eliminate the cause of the fault using a diagnosis unit.

Important instructions for operation

Safety checks before the start

After a longer interval in operations (after the summer months) the fuse must be put in position and / or the heater connected up to the battery. Check that all parts fit firmly (tighten screws where necessary). Check the fuel system visually for any leaks.

Before switching on

Before switching on or pre-programming the heater, adjust the heating control in the vehicle to "WARM" (maximum setting) and the fan to "SLOW" (low power consumption). In vehicles with automatic heating, adjust the heating control to "MAX" and open the heating vents before switching the ignition off.

Description of functions

Switching on

On switching on, the switch on check is displayed in the control (EasyStart R+ / EasyStart T). The heater starts according to a preset program, whereby the water pump and the combustion air fan start up first. The metering pump starts fuel feed somewhat delayed. The glow phase of the glow pencils begins simultaneously with distribution of the combustion air. The glow pencils are switched off if a stable flame has formed in the combustion chamber.

Heating mode

At the initial start the heater is operated with the "POWER" stage until the water temperature exceeds the "POWER" / "HIGH" changeover threshold.

HYDRONIC M8 / M10

Then, depending on the heat requirement, the heater switches to the "HIGH – MEDIUM – LOW – OFF" stages.

If the heating requirement in the "LOW" stage is so small that the cooling water temperature reaches 85 °C, the heater switches from "LOW" to "OFF".

HYDRONIC M12

Then, depending on the heat requirement, the heater switches to the "HIGH – MEDIUM 1 / MEDIUM 2 / MEDIUM 3 – LOW – OFF" stages.

If the heating requirement in the "LOW" stage is so small that the cooling water temperature reaches 85 °C, the heater switches from "LOW" to "OFF".

This is followed by the after-run with additional after glowing of the glow plugs.

After the cooling water has cooled to approx. 70 °C the *HYDRONIC M8 / M10* heater starts in the "MEDIUM" stage, the *HYDRONIC M12* heater in the "MEDIUM 1" stage.

If the cooling water temperature reaches approx. 55 °C the temperature sensor switches the vehicle fan on.

Switching off

On being switched off the heater starts the after-run of 180 sec. During the after-run both of the glow plugs also after glow.

Temperature drop

Temperature lowering only becomes active while the vehicle is running and if the heater (independent heater mode) is switched on. The control stages are reached earlier and the heater's control action is adjusted to the lower heat requirement.

The temperature can be lowered by connecting the positive cable (D+) to connector B2, terminal C3 of the heater cable harness (see circuit diagrams, Page 32 and 34).



4 Operation and function

Control and safety devices

The heater is equipped with the following control and safety devices:

- If the heater does not ignite within 74 seconds after starting the fuel pump, the start is repeated. If the heater still does not ignite after another 65 seconds, the heater is switched off. After an unacceptable number of failed start attempts, the controller is locked.*
- If the flame goes off by itself during operation, the heater is restarted. If the heater does not ignite within 74 seconds after the fuel pump has started again, the heater is switched off. This status can be remedied by briefly switching off and on again.
- In the case of overheating (e.g. lack of water, poorly vented coolant circuit), the overheating sensor triggers, the fuel supply is interrupted and the heater switched off. Once the cause of overheating has been eliminated, the heater can be re-started by switching off and on again (on condition that the heater has cooled down again sufficiently, cooling water temperature <70 °C). After the heater has been switched off for overheating an unacceptable number of times, the controller is locked.*

* The controller can be enabled again and the faults read off:

- using the module timer / EasyStart T
- using the radio remote control TP5 / EasyStart R / EasyStart R+.

For other controls:

- by connecting up a diagnosis unit
- using the diagnosis tool EDITH.

For operation and fault list, please refer to the enclosed operating instructions or the troubleshooting and repair instructions for the heater.

- The heater is switched off if the upper or lower voltage limit is reached.
- The heater does not start up if the electric cable to the metering pump is interrupted.
- If one of the two glow plugs is defective the start sequence takes place with one glow plug only.
- The speed of the fan motor is monitored continuously. If the blower motor does not start up if it is blocked, or if the speed differs by > 12.5 % from the desired speed a safety lockout (shutdown on faults) takes place after 60 sec.
- The water pump's function is continuously monitored.

Please note!

Do not switch the heater off and on again more than twice.

Forced shut-down for ADR / ADR99 operation

In vehicles for the transport of dangerous goods (e.g. tanker trucks), the heater must be switched off before the truck drives into a danger area (refinery, fuel service station, etc.)

Failure to comply results in the heater switching off automatically when:

- The vehicle engine is switched off.
- An additional unit is started up (e.g. auxiliary drive for unloading pump etc.).
- A vehicle door is opened (ADR99 regulation, only in France).

The fan then runs on for max. 40 seconds.

Emergency shutdown – EMERGENCY OFF

If an emergency shutdown – EMERGENCY OFF – is necessary during operation, proceed as follows:

- Switch the heater off with the control or
- pull the fuse out or
- disconnect the heater from the battery.

5 Electrical system

Heater wiring

The heater is to be connected up electrically according to the EMC directives.



Caution! Safety instructions for wiring the heater

EMC can be affected if the heater is not connected up correctly. For this reason, comply with the following instructions:

- Ensure that the insulation of electrical cables is not damaged. Avoid: chafing, kinking, jamming or exposure to heat.
- In waterproof connectors, seal any connector chambers not in use with filler plugs to ensure they are dirt- and water-proof.
- Electrical connections and ground connections must be free of corrosion and firmly connected.
- Lubricate connections and ground connections outside the heater interior with contact grease.

Please note!

Comply with the following when wiring the heater and the control element:

- Electrical leads, switchgear and controllers must be arranged in the vehicle so that they can function perfectly under normal operating conditions (e.g. heat exposure, moisture etc.).
- The following cable cross sections are to be used between the battery and heater. This ensures that the max. tolerable voltage loss in the cables does not exceed 0.5 V for 12 V or 1 V for 24 V rated voltage. Cable cross sections for a cable length of:
 - up to 5 m (plus cable + minus cable) = cable cross section 4 mm²
 - from 5 to 8 m (plus cable + minus cable) = cable cross section 6 mm²
- If the plus cable is to be connected to the fuse box (e.g. terminal 30), the vehicle cable from the battery to the fuse box must be included in rating the overall cable length and possibly re-dimensioned if necessary.
- Insulate unused cable ends.

Notes on rewiring the 12-pin cable harness connector

If, on replacing the *HYDRONIC M* with the *HYDRONIC M-II*, the cable harness already installed in the vehicle is to be reused it is necessary to remove the 12-pin connector using the AMP release tool (AMP Order No. 1-1579007-4) and to rewire it according to the following table.

12-pin connection pin assignment

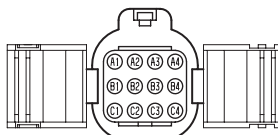

Connector is shown from the cable entry side.

Connection	Cable harness <i>HYDRONIC M</i> Cross-section Cable colour	Rewiring 12-pin connector	
		<i>HYDRONIC M</i> PIN	<i>HYDRONIC M-II</i> PIN
Dosing pump	1,5 ² gn	C4 →	A1
Terminal 31	4 ² br	C3 →	A2
Terminal 30	4 ² rt	C2 →	A3
Plus signal Main battery switch	1,5 ² ws/rt	C1 →	A4
Plus signal Solenoid valve relay	–	B4 →	B1
Diagnosis	1 ² bl	B3 →	B4
Plus signal ADR auxiliary drive	1 ² vi	B2 →	B3
External control Water pump	–	B1 →	B2 remains unused*
Relay, blower	1 ² rt/ge	A4 →	C1
D+ for ADR mode	1 ² vi/gn	A3 →	C2
Temperature drop	–	A2 →	C3
Heater ON	1 ² ge	A1 →	C4

*External control of the water pump is not planned for *HYDRONIC M-II*.



5 Electrical system

Parts list for the circuit diagrams HYDRONIC M-II – 12 Volt / 24 Volt

- 1.1 Burner engine
- 1.2 Glow plug 1
- 1.2.1 Glow plug 2 (optional 12kW /FAME)
- 1.5 Overheating sensor
- 1.12 Flame sensor
- 1.13 Temperature sensor
- 2.1 Controller
- 2.2 Dosing pump
- 2.5.7 Relay, vehicle fan
- 2.5.18 Relay, water circuit change-over –
to be fitted by the customer as required.
- 2.7 Main fuse 12 volt = 20 A
 24 volt = 15 A
- 2.7.1 Fuse, actuation 5A
- 2.7.5 Fuse, vehicle fan 25 A
- 2.12 Water pump
- 5.1 Battery
- 5.10 Vehicle fan
- a) Connection for control unit

12-pin connection pin assignment (external)

PIN-No.	Connection	Cable cross-section mm ²
A1	Dosing pump	1.5
B1	Solenoid valve, optional	1.0
C1	Relay, blower	1.0
A2	Terminal 31	4.0
B2	Diagnosis cable (OEM)	1.0
C2	unused	–
A3	Terminal 30	4.0
B3	unused	–
C3	Temperature drop	1.0
A4	Vext.	1.5
B4	Diagnosis (HELIJED)	1.0
C4	Heater ON	1.0

- b) Water circuit change-over: Relay makes contact at 68 °C and breaks contact at 63 °C water temperature (with temperature drop 58 °C / 45 °C)
- c) Heater connection
- d) Temperature drop (with positive signal)
- e) Connect the cables in the control's connector
- x) Disconnect cable
- a2) Diagnosis
- a3) Switch-on signal S+
- a4) Power supply plus, +30
- a5) Power supply minus, –31
- a6) (+) Release the battery disconnecting switch (diode: order no. 208 00 012)

Connectors and bush housings are shown from the cable inlet side.

Please note!

Note on switching on signal S+:

- For control units EasyStart R+ / R / T
 - Connect cable 0.75² bl/ws in connector B2, chamber B4
- For all other controls
 - Connect cable 1² ge in connector B2, chamber B4
- See page 32 for circuit diagram.

Cable colours

- rt = red
- bl = blue
- ws = white
- sw = black
- gn = green
- gr = grey
- ge = yellow
- vi = violet

5 Electrical system

Circuit diagram *HYDRONIC M-II* – 12 Volt / 24 Volt

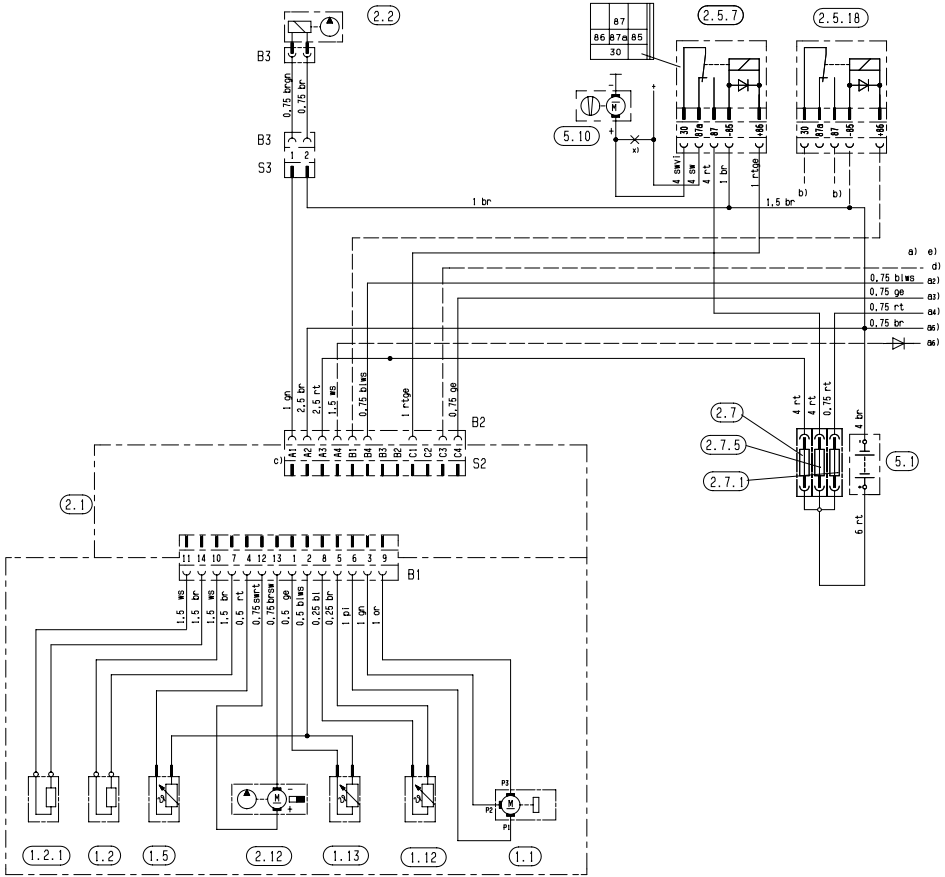

B1

B2

B3

S2

S3

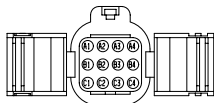
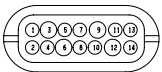



5 Electrical system

Parts list for the circuit diagrams

HYDRONIC M-II, 12 Volt / 24 Volt, ADR

- 1.1 Burner motor
- 1.2 Glow plug 1
- 1.2.1 Glow plug 2
- 1.5 Overheating switch
- 1.12 Flame sensor
- 1.13 Temperature sensor
- 2.1 Controller
- 2.2 Fuel dosing pump
- 2.5.7 Relay, vehicle fan
- 2.5.18 Relay, changeover water circuit
To be fitted by customer if required
- 2.7 Main fuse 12 volt = 20 A
24 volt = 15 A
- 2.7.1 Fuse, actuation 5 A
- 2.7.5 Fuse, vehicle fan 25 A
- 2.12 Water pump
- 5.1 Battery
- 5.2.1 Battery main switch (operation e.g. separate from ignition lock), g)
- 5.2.2 Battery disconnection switch (EMERGENCY OFF function for ADR), g)
- 5.10 Vehicle fan

a) Connection for control

12-pin connection pin assignment (external)

PIN-No.	Connection	Cable cross-section mm ²
A1	Dosing pump	1.5
B1	Solenoid valve, optional	1.0
C1	Relay, blower	1.0
A2	Terminal 31	4.0
B2	Diagnosis cable (OEM)	1.0
C2	D+	–
A3	Terminal 30	4.0
B3	TRS signal (ADR)	1.0
C3	Temperature drop	1.0
A4	Vext.	1.5
B4	Diagnosis (HELJED)	1.0
C4	Heater ON	1.0

- b) For ADR D+ (dynamo)
- c) For ADR HA+ (auxiliary drive/ secondary drive) minus circuit, if not present, route lead to +
- d) Changeover water circuit: relay closes at 68 °C and opens at 63 °C water temperature (with temperature decrease 58 °C / 45 °C)
- e) Connection heater
- f) Temperature drop (with plus signal)
- g) If only one switching element is used for items 5.2.1 and 5.2.2, it is necessary to ensure that on pressing the battery disconnecting switch (EMERGENCY OFF function in ADR), the switch always breaks contact immediately (regardless of the heater condition) and all the heater's circuits are disconnected from the battery.

- h) Connect the cables in the control's connector
- x) Disconnect lead
- a1) ADR feedback
- a2) Dagnosis
- a3) Switch-on signal S+
- a4) Power supply plus +30
- a5) Power supply minus -31
- a6) (+) Trigger battery disconnecting switch (diode: order no. 208 00 012)

Connectors and bush housings are shown from the cable inlet side.

Please note!

Note on switching on signal S+:

- For control units EasyStart R+ / R / T
 - Connect cable 0.75² bl/ws in connector B2, chamber B4
- For all other controls
 - Connect cable 1² ge in connector B2, chamber B4
- See page 34 for circuit diagram.

Cable colours

- rt = red
- bl = blue
- ws = white
- sw = black
- gn = green
- gr = grey
- ge = yellow
- vi = violet

5 Electrical system

Circuit diagram *HYDRONIC M-II*, 12 Volt / 24 Volt, ADR

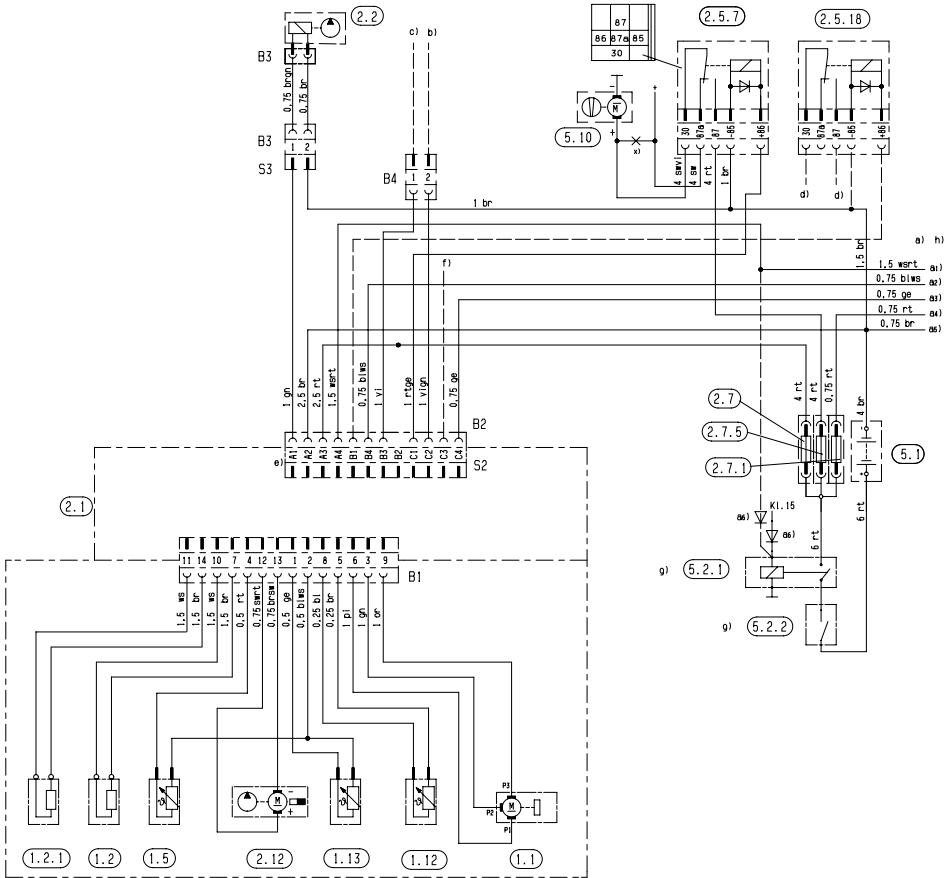

B1

B2

B3

S2

S3

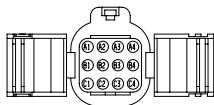
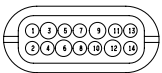



5 Electrical system

Parts list for the circuit diagrams for the control elements EasyStart R+ / EasyStart R / EasyStart T and EasyStart T – ADR

- 2.15.1 Temperature sensor (room temperature)
(included in the EasyStart R+ scope of supply, optional for EasyStart T)
- 2.15.9 External temperature sensor
- 3.1.7 "ON / OFF" button
- 3.1.16 Radio remote control button
- 3.2.15 EasyStart T timer
- 3.3.9 EasyStart R radio remote control
(stationary unit)
- 3.3.10 EasyStart R+ radio remote control
(stationary unit)
- 3.6.1 Adapter cable
- 3.8.3 Antenna

- c) Terminal 58 (lighting)
- e) EasyStart T timer connection
- g) External "ON / OFF" button (optional)
- x) ADR jumper

Please note!

- The timer / radio remote control must be connected in accordance with the circuit diagrams (page 36 – 39).
- Insulate unused cable ends.
- Connectors and bush housings are shown from the cable inlet side.

Cable colours

- rt = red
- bl = blue
- ws = white
- sw = black
- gn = green
- gr = grey
- ge = yellow
- vi = violet

5 Electrical system

Circuit diagram for the control element EasyStart R+

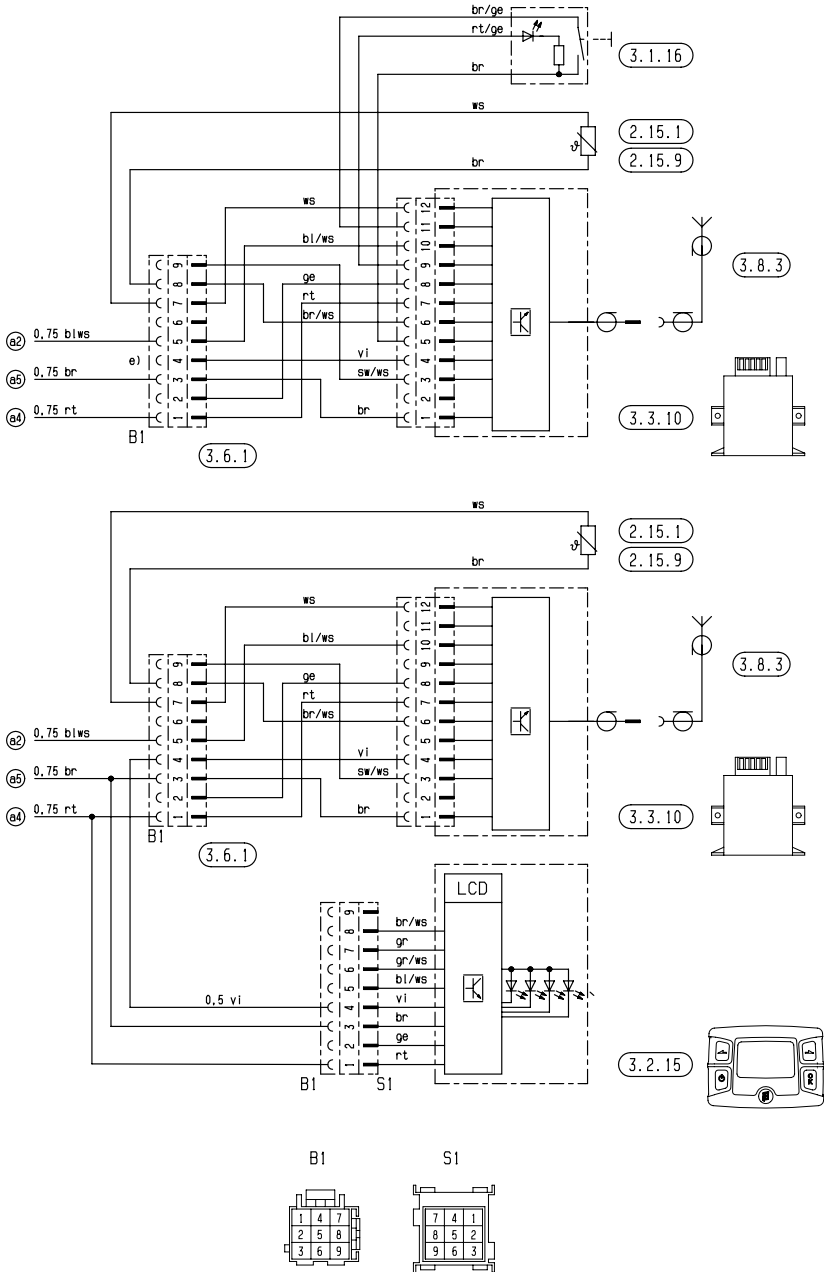



5 Electrical system

Circuit diagram for the control element EasyStart R

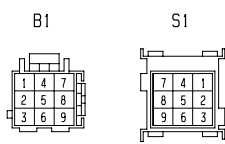
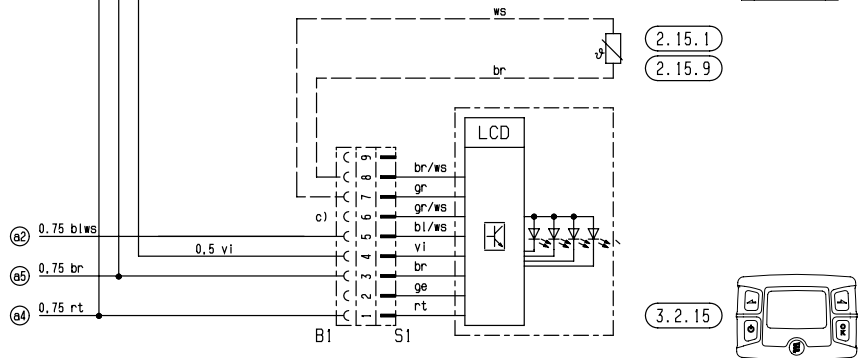
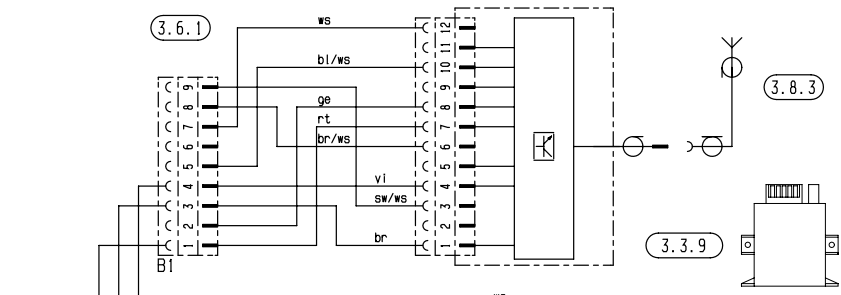
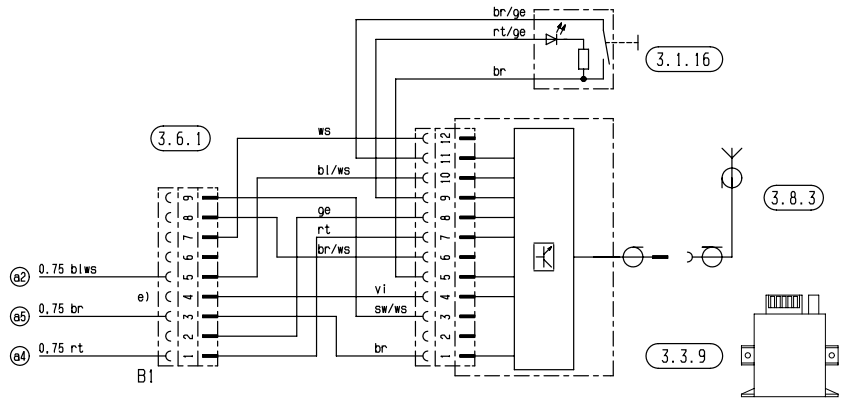

5 Electrical system

Circuit diagram for the control element EasyStart T

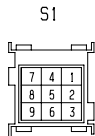
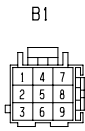
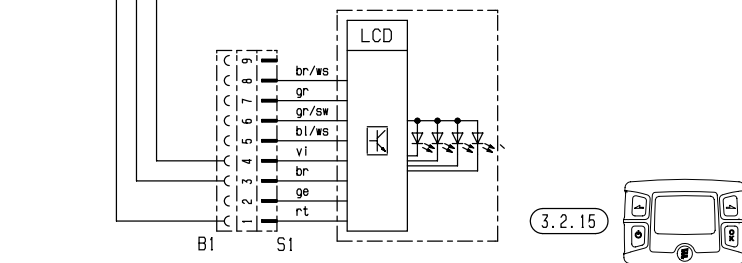
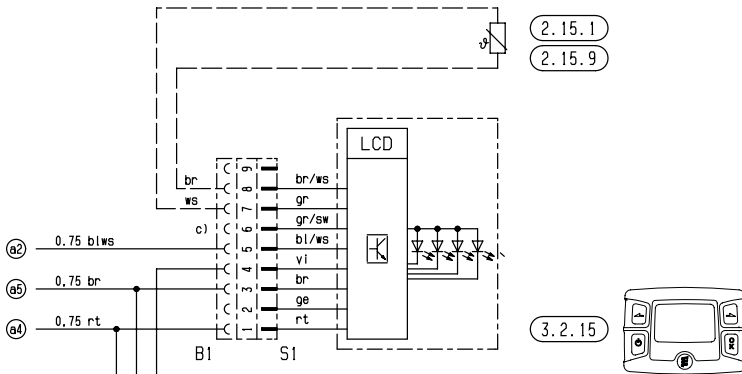
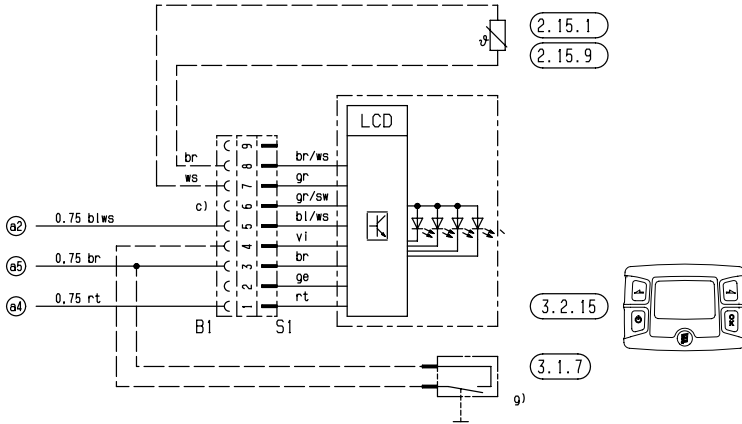



5 Electrical system

Circuit diagram for the control element EasyStart T – ADR

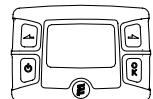
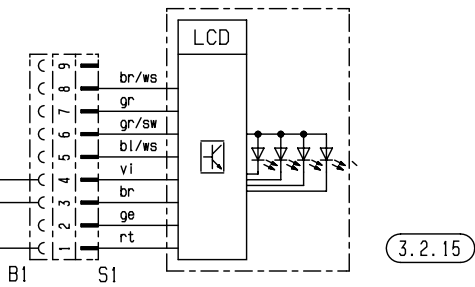
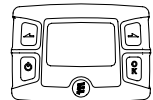
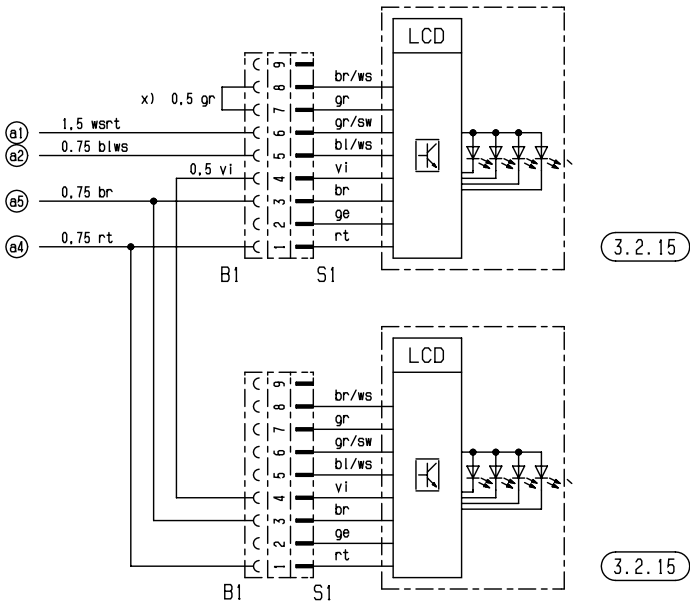
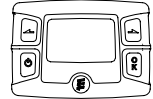
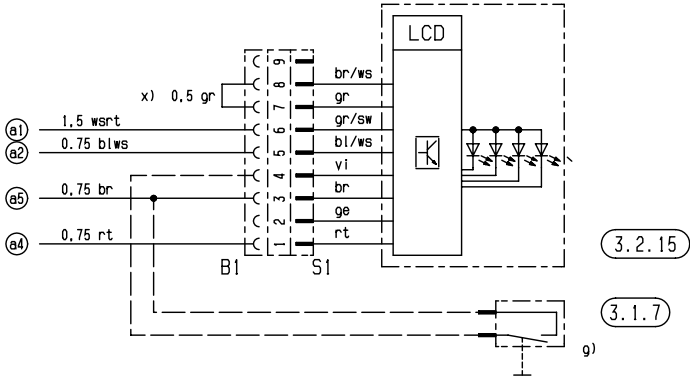

B1

S1

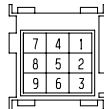

6 Troubleshooting / Maintenance / Service

In case of faults, please check the following points

- If the heater does not start after being switched on:
 - Switch the heater off and on again.
- If the heater still does not start, check whether:
 - There is fuel in the tank?
 - The fuses are OK?
 - The electrical cables, connections etc. are OK?
 - Anything is clogging the combustion air supply or exhaust system?
- Check the openings of the combustion air supply and exhaust system after longer standstill periods, clean if necessary!

Troubleshooting

If the heater remains faulty even after these points have been checked, or another malfunction occurs in your heater, please contact:

- For installation ex works, your contract workshop.
- For subsequent installation, the workshop who installed your heater.

Please note!

Please note that warranty claims can be become void if the heater is changed by a third party or by this installation of third party parts.

Maintenance instructions

- Switch the heater on once a month for about 10 minutes, even outside the heating period.
- Before the heating period starts, the heater should undergo a trial run. If persistent extreme smoke develops, unusual burning noises or a clear fuel smell can be perceived or if electric / electronic parts heat up, the heater must be switched off and put out of service by removing the fuse.
In this case, the heater should not be started up again until it has been checked by qualified staff who have been trained on Eberspächer heaters.

Service

If you have any technical queries or problems with your pre-heater, dial the following service phone number:

Hotline
Phone 00 49 (0)800 / 12 34 300

Fax hotline
Fax 00 49 (0)1805 / 26 26 24

Outside of Germany, please contact the respective national Eberspächer service agent.



7 Environment

Certification

The high quality of Eberspächer's products is the key to our success.

To guarantee this quality, we have organised all work processes in the company along the lines of quality management (QM).

Even so, we still pursue a large number of activities for continuous improvement of product quality in order to keep pace with the similarly constantly growing requirements made by our customers.

All the steps necessary for quality assurance are stipulated in international standards.

This quality is to be considered in a total sense.

It affects products, procedures and customer/supplier relationships.

Officially approved public experts assess the system and the corresponding certification company awards a certificate.

Eberspächer has already qualified for the following standards:

**Quality management as per
DIN EN ISO 9001:2000 and ISO/TS 16949:1999**

**Environment management system as per
DIN EN ISO 14001:1996**

Disposal

Disposal of materials

Old devices, defect components and packaging material can all be separated and sorted into pure-grade fractions so that all parts can be disposed of as required in an environment-friendly manner or recycled where applicable.

Electric motors, controllers and sensors (e.g. temperature sensors) are deemed to be "electronic scrap".

Dismantling the heater

The heater is dismantled according to the repair stages in the current troubleshooting / repair instructions.

Packaging

The packaging of the heater can be kept in case it has to be sent back.

EU Declaration of Conformity

With regard to the following products

Heater type *HYDRONIC M-II*

we herewith confirm that it conforms with the prime safety requirements stipulated in the directives of the EU Council for harmonisation of the legal regulations of the member states with regard to electromagnetic compatibility (89 / 336 / EEC).

This declaration applies to all heaters produced according to the production drawings *HYDRONIC M-II* which are an integral part of this declaration.

The following standards / directives have been used to assess the product with regard to electromagnetic compatibility:

- EN 50081 – 1 Basic form interference emission.
- EN 50082 – 1 Basic form interference resistance.
- 72 / 245 / EEC – Modification status 2006 / 28 / EG interference suppression in motor vehicles.

8 Lists

List of key words A – Z

Keyword	Page	Keyword	Page
A		I	
Accident prevention.....	7	Intake side.....	24, 25
ADR.....	2, 4, 6, 14, 29	Installation.....	14
ADR99.....	29	Interference suppression class.....	10 – 12
Ambient temperature.....	10 – 12	Initial commissioning.....	28
Arrangement.....	5	Installation location.....	14
B		Installation example.....	14
Biodiesel.....	10, 27	Installation position.....	15, 24, 26
C		L	
Certification.....	41	List of abbreviations.....	43
Circuit diagrams.....	31, 33, 35 – 38	M	
Combustion air.....	22	Main dimensions.....	13
Combustion air intake.....	5	Maintenance instructions.....	40
Combustion air system.....	22	Minimum water flow rate.....	10 – 12
Contents.....	2	N	
Cooling water circuit.....	17 – 19	Nameplate.....	16
Control of heat flow.....	10 – 12	Non-return valve.....	18
Controls.....	7, 29	Normal position.....	15
D		O	
Dangerous goods.....	2, 4, 6, 14, 29	Operating instructions.....	28
Declaration of conformity.....	41	Operating range.....	10 – 12
Description of functions.....	28	Operating pressure.....	10 – 12
Disposal.....	41	Operating status.....	5
Diesel, commercially available.....	10 – 12	P	
Dosing pump.....	10 – 12, 23 – 26	Parts list.....	31, 33, 35
E		Picture symbols.....	4
Electrical power consumption.....	10 – 12	Power consumption.....	10 – 12
Emergency off.....	29	Pressure side.....	24, 25
EMC directives.....	30	Pressure height.....	26
Environment.....	41	Purpose.....	4
Exhaust.....	11	R	
Exhaust system.....	5, 21	Rated voltage.....	10 – 12
F		Range of application.....	4
Faults.....	28, 40	Regulations.....	4, 5, 6
Fastening.....	15	S	
Fax hotline.....	40	Safety check.....	28
Forced shut-down.....	29	Scope of supply.....	8, 9
Fuses.....	30, 32	Service.....	40
Fuel feed pipe.....	24	Solenoid valve.....	19
Fuel quality.....	27	Switching on.....	28
Fuel consumption.....	10 – 12	T	
Fuel supply.....	5, 23 – 27	Tank connection.....	25
Fuel tank.....	23	Tank fitting.....	24
H		Technical data.....	10 – 12
Heat flow.....	10 – 12	Thermostat.....	19
Heating operation.....	28	T-piece.....	19, 20
Heating characteristics.....	18 – 20	Troubleshooting.....	40
Heating medium.....	10 – 12	U	
Heating period.....	40	Universal installation kit.....	8
Hotline.....	40		



Keyword	Page
V	
Voltage limit	10 – 12
W	
Water flow rate	10 – 12
Water inlet	13
Water outlet	13
Weight	10 – 12
Wiring	30

List of abbreviations

ADR

European agreement about the international transport of dangerous goods on the road.

EC type approval

Permit awarded by the Federal Vehicle Office for the production of a heater for installation in motorised vehicles.

EMC directive

Electromagnetic compatibility.

JE partner

J. Eberspächer partner.

FAME (Biodiesel)

(FAME for diesel engines according to DIN EN 14 214)

www.eberspaecher.com

J. Eberspächer
GmbH & Co. KG
Eberspächerstraße 24
D-73730 Esslingen
Telefon 0711 939-00
Telefax 0711 939-0643
info@eberspaecher.com



Eberspächer®