

VARIPROP

Fig. 1

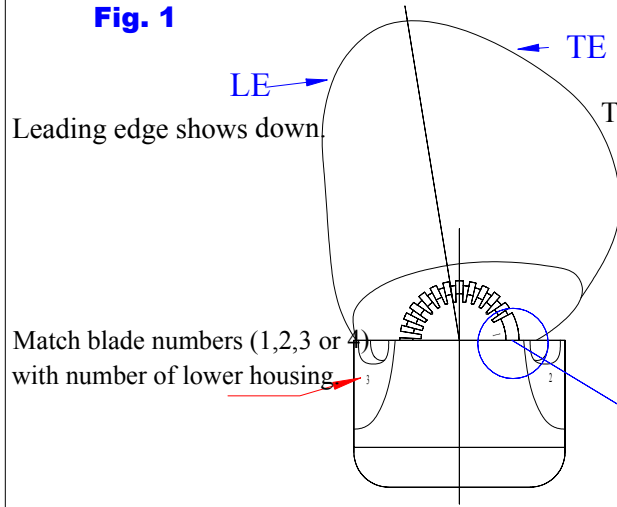

Trailing edge shows up. LH (left hand)

Assembly: Please observe the position of the locator pin and hole marked X

Fig. 2

Section A-A

Turn inner hub (4) LH to the stop inside the lower housing (2).

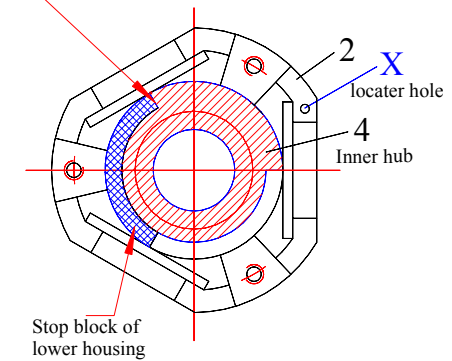
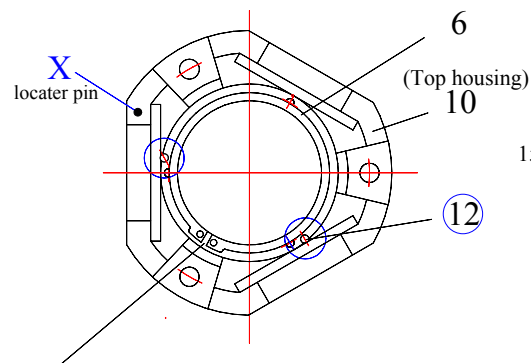

Fig. 3 Section B-B

Assembly part 10, part 6 and part 12.



Important note:

Place the open Part of the circlips (6) between the smaller distance of the 2 stop screws (12)

Fig. 4

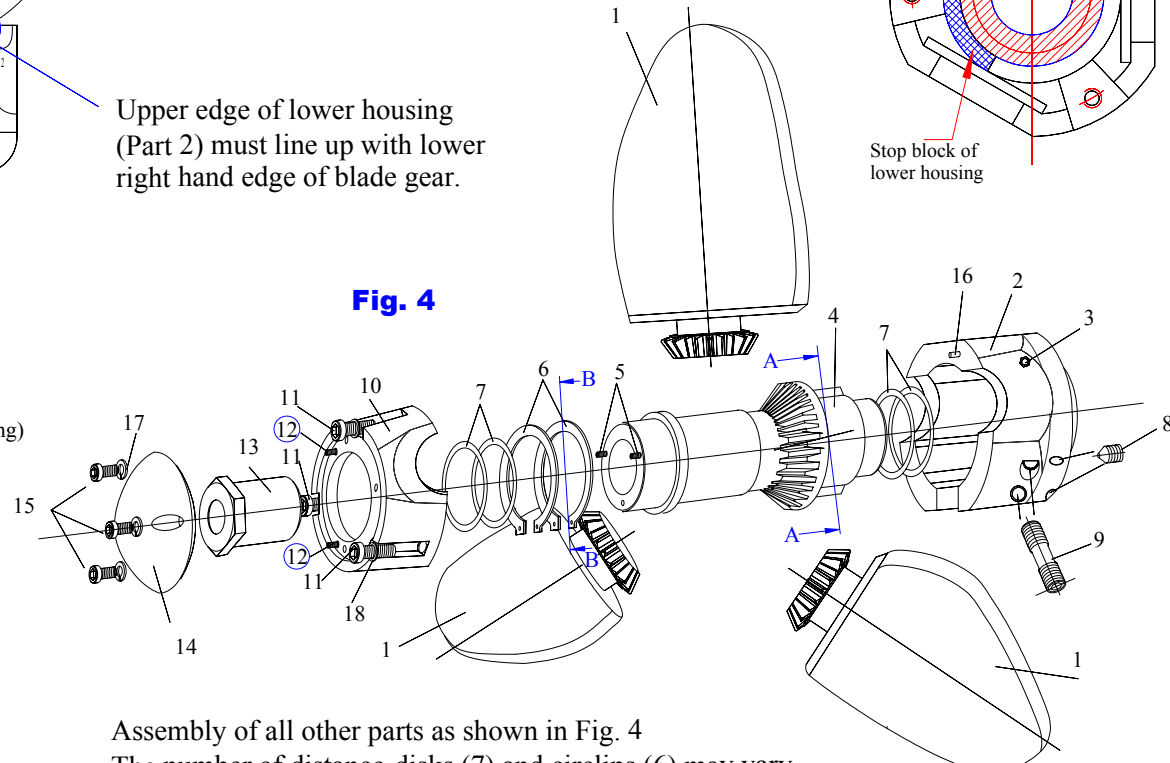

Assembly of all other parts as shown in Fig. 4
The number of distance-disks (7) and circlips (6) may vary.